

## 7404, LS04, S04 Inverters

Hex Inverter  
Product Specification

Logic Products

TYPE	TYPICAL PROPAGATION DELAY	TYPICAL SUPPLY CURRENT (TOTAL)
7404	10ns	12mA
74LS04	9.5ns	2.4mA
74S04	3ns	22mA

### ORDERING CODE

PACKAGES	COMMERCIAL RANGE $V_{CC} = 5V \pm 5\%$ ; $T_A = 0^{\circ}C$ to $+70^{\circ}C$
Plastic DIP	N7404N, N74LS04N, N74S04N
Plastic SO	N74LS04D, N74S04D

### FUNCTION TABLE

INPUT	OUTPUT
A	Y
L	H
H	L

H = HIGH voltage level  
L = LOW voltage level

### NOTE:

For information regarding devices processed to Military Specifications, see the Signetics Military Products Data Manual.

### INPUT AND OUTPUT LOADING AND FAN-OUT TABLE

PINS	DESCRIPTION	74	74S	74LS
A	Input	1uI	1SuI	1LSuI
Y	Output	10uI	10SuI	10LSuI

### NOTE:

Where a 74 unit load (uI) is understood to be  $40\mu A I_{IH}$  and  $-1.6mA I_{IL}$ , a 74S unit load (SuI) is  $50\mu A I_{IH}$  and  $-2.0mA I_{IL}$ , and 74LS unit load (LSuI) is  $20\mu A I_{IH}$  and  $-0.4mA I_{IL}$ .

### PIN CONFIGURATION

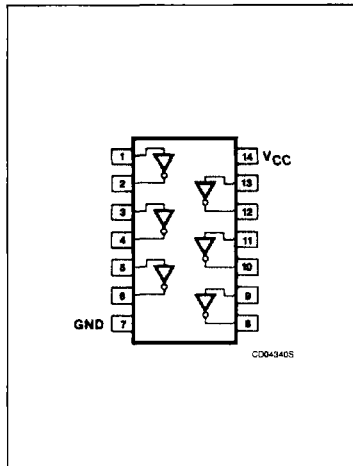

### LOGIC SYMBOL

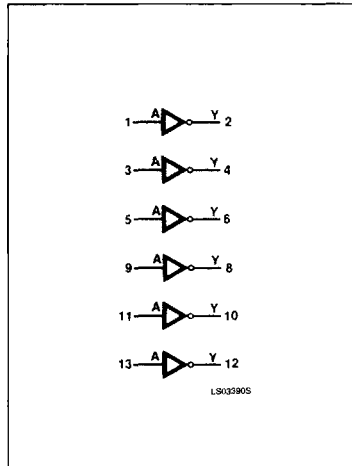

### LOGIC SYMBOL (IEEE/IEC)

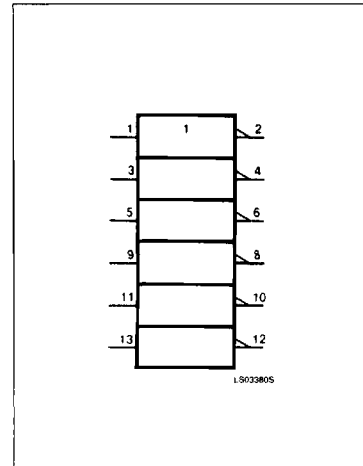

# Inverters

# 7404, LS04, S04

### ABSOLUTE MAXIMUM RATINGS (Over operating free-air temperature range unless otherwise noted.)

PARAMETER	74	74LS	74S	UNIT
V <sub>CC</sub> Supply voltage	7.0	7.0	7.0	V
V <sub>IN</sub> Input voltage	-0.5 to +5.5	-0.5 to +7.0	-0.5 to +5.5	V
I <sub>IN</sub> Input current	-30 to +5	-30 to +1	-30 to +5	mA
V <sub>OUT</sub> Voltage applied to output in HIGH output state	-0.5 to +V <sub>CC</sub>	-0.5 to +V <sub>CC</sub>	-0.5 to +V <sub>CC</sub>	V
T <sub>A</sub> Operating free-air temperature range	0 to 70			°C

### RECOMMENDED OPERATING CONDITIONS

PARAMETER	74			74LS			74S			UNIT
	Min	Nom	Max	Min	Nom	Max	Min	Nom	Max	
V <sub>CC</sub> Supply voltage	4.75	5.0	5.25	4.75	5.0	5.25	4.75	5.0	5.25	V
V <sub>IH</sub> HIGH-level input voltage	2.0			2.0			2.0			V
V <sub>IL</sub> LOW-level input voltage			+0.8			+0.8			+0.8	V
I <sub>IK</sub> Input clamp current			-12			-18			-18	mA
I <sub>OH</sub> HIGH-level output current			-400			-400			-1000	µA
I <sub>OL</sub> LOW-level output current			16			8			20	mA
T <sub>A</sub> Operating free-air temperature	0		70	0		70	0		70	°C

### TEST CIRCUITS AND WAVEFORMS

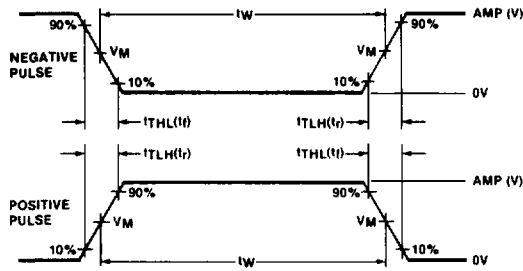
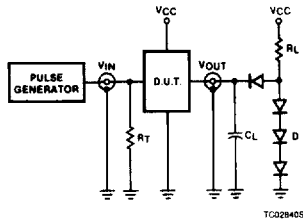

V<sub>M</sub> = 1.3V for 74LS; V<sub>M</sub> = 1.5V for all other TTL families.

#### Test Circuit For 74 Totem-Pole Outputs

#### DEFINITIONS

R<sub>L</sub> = Load resistor to V<sub>CC</sub>; see AC CHARACTERISTICS for value.

C<sub>L</sub> = Load capacitance includes jig and probe capacitance; see AC CHARACTERISTICS for value.

R<sub>T</sub> = Termination resistance should be equal to Z<sub>OUT</sub> of Pulse Generators.

D = Diodes are 1N916, 1N3064, or equivalent.

t<sub>TLH</sub>, t<sub>THL</sub> Values should be less than or equal to the table entries.

#### Input Pulse Definition

FAMILY	INPUT PULSE REQUIREMENTS				
	Amplitude	Rep. Rate	Pulse Width	t <sub>TLH</sub>	t <sub>THL</sub>
74	3.0V	1MHz	500ns	7ns	7ns
74LS	3.0V	1MHz	500ns	15ns	6ns
74S	3.0V	1MHz	500ns	2.5ns	2.5ns

# Inverters

# 7404, LS04, S04

## DC ELECTRICAL CHARACTERISTICS (Over recommended operating free-air temperature range unless otherwise noted.)

PARAMETER	TEST CONDITIONS <sup>1</sup>	7404			74LS04			74S04			UNIT
		Min	Typ <sup>2</sup>	Max	Min	Typ <sup>2</sup>	Max	Min	Typ <sup>2</sup>	Max	
V <sub>OH</sub>	HIGH-level output voltage V <sub>CC</sub> = MIN, V <sub>IL</sub> = MAX, I <sub>OH</sub> = MAX	2.4	3.4		2.7	3.4		2.7	3.4		V
V <sub>OL</sub>	LOW-level output voltage V <sub>CC</sub> = MIN, V <sub>IH</sub> = MIN	I <sub>OL</sub> = MAX				0.35	0.5			0.5	V
		I <sub>OL</sub> = 4mA (74LS)				0.25	0.4				V
V <sub>IK</sub>	Input clamp voltage V <sub>CC</sub> = MIN, I <sub>I</sub> = I <sub>IK</sub>			-1.5			-1.5			-1.2	V
I <sub>I</sub>	Input current at maximum input voltage V <sub>CC</sub> = MAX	V <sub>I</sub> = 5.5V			1.0					1.0	mA
		V <sub>I</sub> = 7.0V					0.1				mA
I <sub>IH</sub>	HIGH-level input current V <sub>CC</sub> = MAX	V <sub>I</sub> = 2.4V			40						μA
		V <sub>I</sub> = 2.7V					20		50		μA
I <sub>IL</sub>	LOW-level input current V <sub>CC</sub> = MAX	V <sub>I</sub> = 0.4V			-1.6		-0.4				mA
		V <sub>I</sub> = 0.5V							-2.0		mA
I <sub>OS</sub>	Short-circuit output current <sup>3</sup> V <sub>CC</sub> = MAX	-18		-55	-20		-100	-40		-100	mA
I <sub>CC</sub>	Supply current (total) V <sub>CC</sub> = MAX	I <sub>CCH</sub>	Outputs HIGH	6	12	1.2	2.4	15	24		mA
		I <sub>CCL</sub>	Outputs LOW	18	33	3.6	6.6	30	54		mA

**NOTES:**

- For conditions shown as MIN or MAX, use the appropriate value specified under recommended operating conditions for the applicable type.
- All typical values are at V<sub>CC</sub> = 5V, T<sub>A</sub> = 25°C.
- I<sub>OS</sub> is tested with V<sub>OUT</sub> = +0.5V and V<sub>CC</sub> = V<sub>CC</sub> MAX + 0.5V. Not more than one output should be shorted at a time and duration of the short circuit should not exceed one second.

## AC WAVEFORM

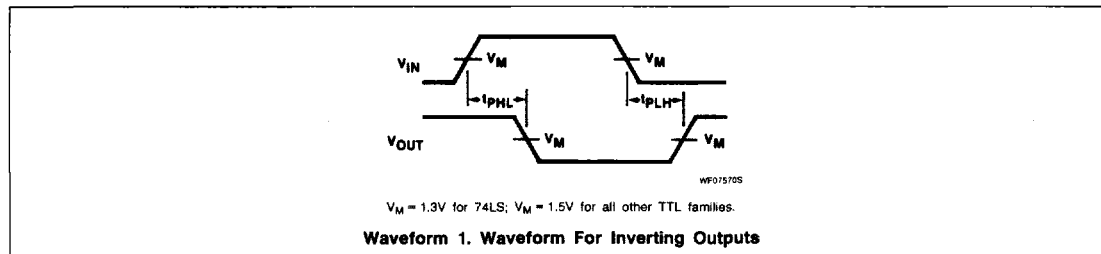

## AC ELECTRICAL CHARACTERISTICS T<sub>A</sub> = 25°C, V<sub>CC</sub> = 5.0V

PARAMETER	TEST CONDITIONS	74		74LS		74S		UNIT
		C <sub>L</sub> = 15pF, R <sub>L</sub> = 400Ω		C <sub>L</sub> = 15pF, R <sub>L</sub> = 2kΩ		C <sub>L</sub> = 15pF, R <sub>L</sub> = 280Ω		
		Min	Max	Min	Max	Min	Max	
t <sub>PLH</sub> t <sub>PHL</sub>	Propagation delay Waveform 1		22 15		15 15		4.5 5.0	ns